



- TELAIO A LAME DIAMANTATE
- MULTIBLADE GANG SAW
- CHASSIS A LAME DIAMANTEES
- TELAR DE HOJAS DIAMANTADAS

**BM 80/100
SUPER 800**



BM s.r.l. - Via 4 Novembre, 37
Montorso Vicentino (Vicenza) - Italy
Tel. +39 0444 485000 - Fax +39 0444 485085
www.bmofficine.it - bmofficine@bmofficine.it



BM 80/100 SUPER 800



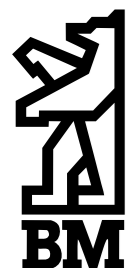

Gruppo batteria

Battery unit • La batterie • Grupo batería

I supporti sono stati progettati in modo tale da facilitare il controllo, la registrazione e l'eventuale sostituzione dei cuscinetti in essa contenuti, senza dover rompere le fondazioni in cemento armato.

Il volano ha un peso di 8 tonnellate e un diametro di 3300 mm.

The battery supports have been designed to allow easy maintenance and facilitate the replacement of the roller bearings without having to break the cement foundations.

The flywheel weighs 8 tons and has a diameter of 3300 mm.

Les supports de la batterie ont été conçus pour un entretien facile et pour permettre le remplacement des roulements à galets sans avoir à casser les fondations en ciment.

Le volant, d'un diamètre de 3300 mm, pèse 8 tonnes.

Los soportes han sido proyectados para facilitar el control, el ajuste y la eventual sustitución de lo cojinetes contenidos en la batería, sin tener que romper los cimientos de cemento armado.

El volante tiene un peso de 8 toneladas y un diámetro de 3300 mm.

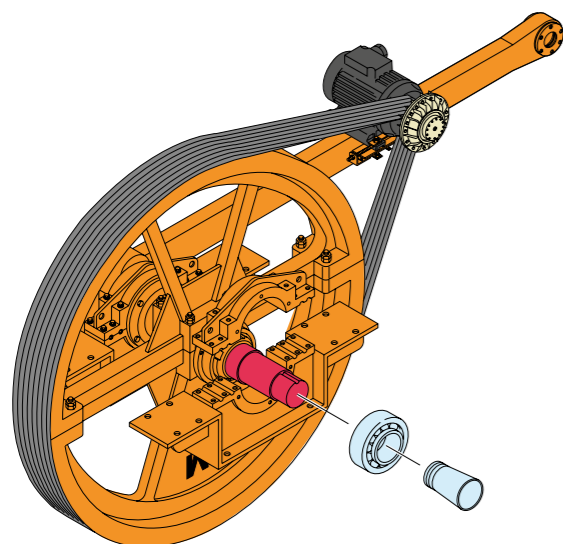

Guide rettilinee articolate

Straight articulated guides • Glissières droites articulées • Guías rectilíneas articuladas

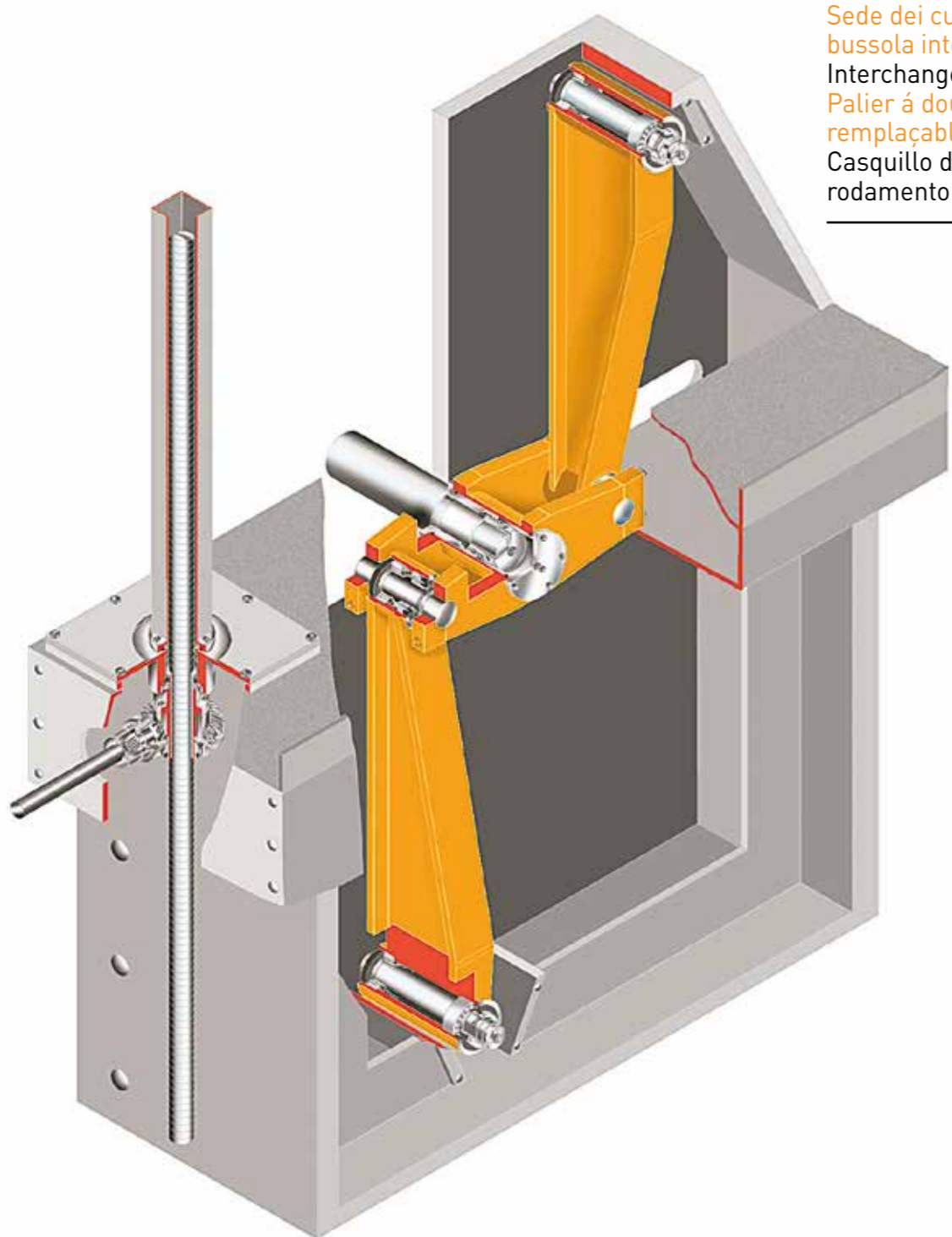

Sede dei cuscinetti su bussola intercambiabile
 Interchangeable bush
 Palier à douille remplaçable
 Casquillo de rodamiento reemplazable

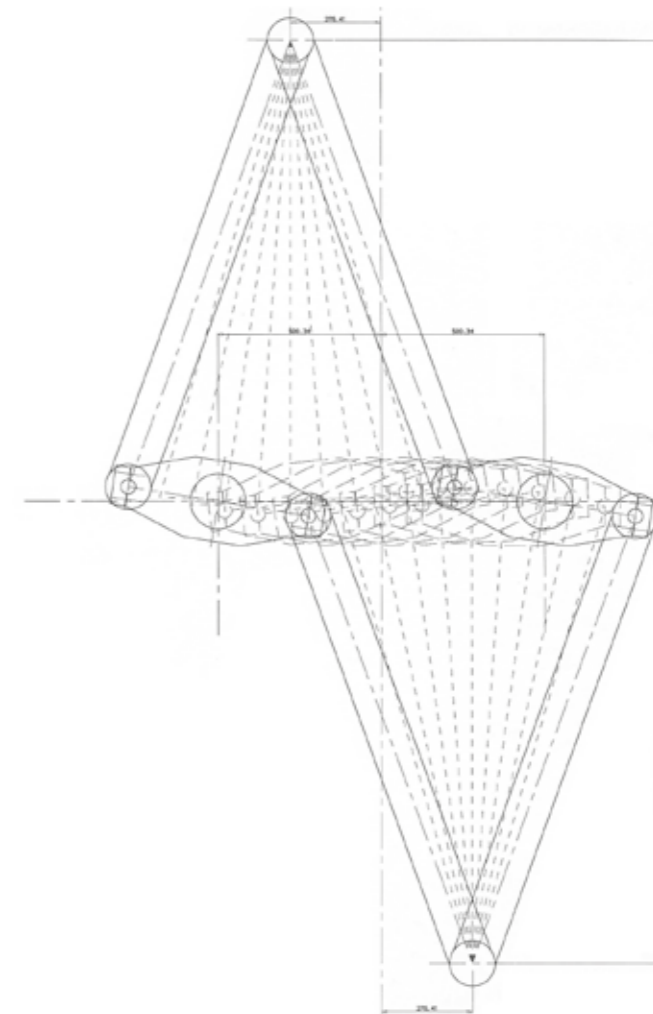
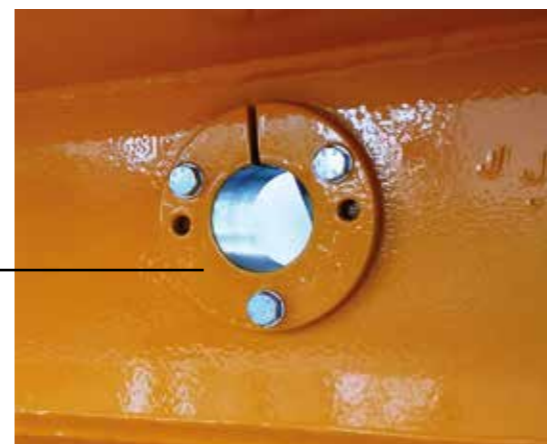

Il quadro portalamme scorre su delle GUIDE RETTILINEE ARTICOLATE grazie alle quali è stato RIDOTTO A "0" IL COSTO DI MANUTENZIONE, in quanto non hanno bisogno di essere sostituite costantemente come le tradizionali slitte.

The blade holder unit slides on STRAIGHT ARTICULATED GUIDES for which MAINTENANCE COSTS HAVE BEEN ELIMINATED, as they do not need to be constantly replaced as traditional slides.

Le cadre porte-lames se déplace sur des GLISSIÈRES DROITES ARTICULÉES GRÂCE AUX QUELLES LE COÛT D'ENTRETIEN EST COMPLÈTEMENT ÉLIMINÉ car elles ne demandent pas de remplacements continus comme les coulisseaux raditionnels.

El cuadro portacuchillas se desliza sobre GUÍAS RECTILÍNEAS ARTICULADAS GRACIAS A LAS CUALES EL COSTE DE MANTENIMIENTO SE HA REDUCIDO A CERO, ya que no es necesario sustituir las constantemente como las tradicionales correderas.



Larghezza • Width
Largeur • Ancho

mm. 1800/2000/2500

Trasmissione maggiorata

Upgraded transmission system • Transmission renforcée • Transmisión reforzada

Slitte rettificate e cromate

Retified and chrome-plated slides • Glissères Rectifiés et chromées • Pismas rectificados y cromados

1. Piattaforma rinforzata
2. Coppia conica installata in alto dentro la colonna e così protetta da acqua e fango
3. Riduttori maggiorati
4. Vitoni fissi protetti da lamiera zincata

1. Reinforced platform
2. Pair of bevel gears installed on top inside the column so protected from mud and water
3. Oversized reduction-gears units
4. Fixed worm-screws protected by galvanized sheets

1. Plate-forme renforcée
2. Couple conique gleason installée dans la colonne et ci protégée da l'au e da la boue
3. Réducteurs plus grand
4. Vis de soulevement protégé par feuilles galvanisées

1. Plataforma reforzada
2. Par de engranajes cónicos reforzados instalado dentro la columna así que protegido de agua y barro
3. Reductores aumentados
4. Tornillos de levantamiento protegidos por chapas galvanizadas

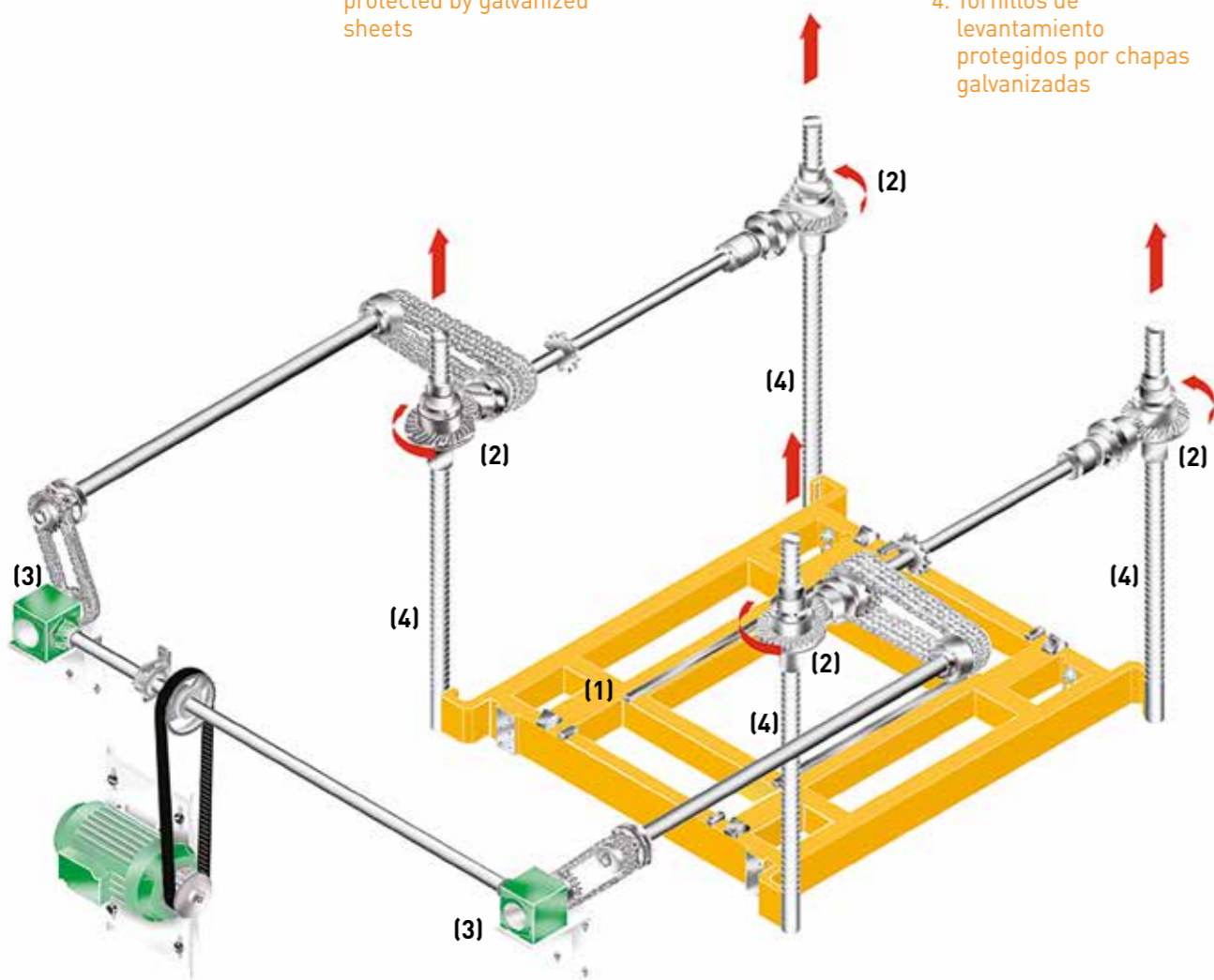

Gruppo di sollevamento del carrello portabloccchi CON INVERTER.

Lifting system WITH INVERTER of the block trolley platform.

Le système de levage, AVEC L'INVERTISSEUR de fréquence de la plateforme.

Grupo de levantamiento del carro portabloques CON INVERTER.

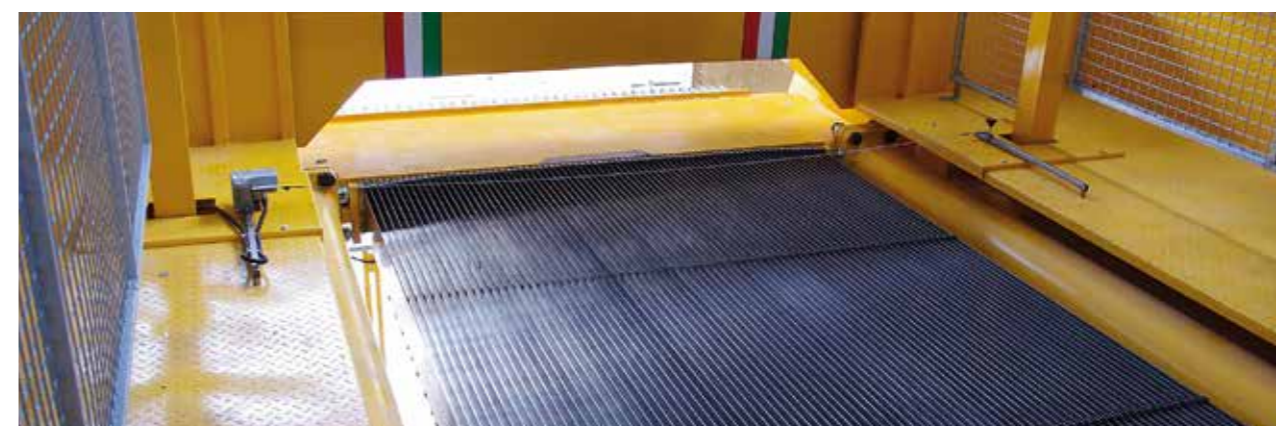

Le bielle

The connecting rods • Les bielles • Las bielas

Distribuzione equilibrata della potenza.
Nessun attrito

Equal distribution of mechanical thrust over all machine components.
No friction

La poussée mécanique est étendue de manière égale, à tous les éléments de la machine.
Au friction

Distribucion equilibrada de la potencia.
Nay fricción

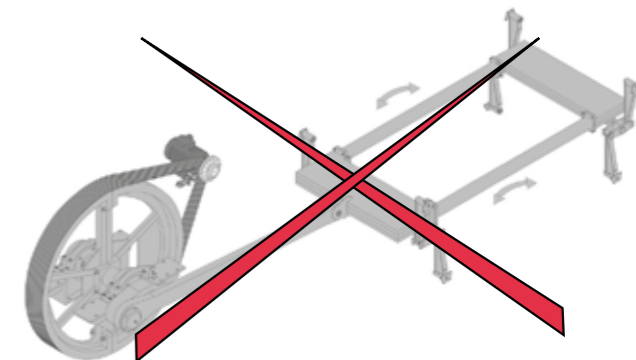
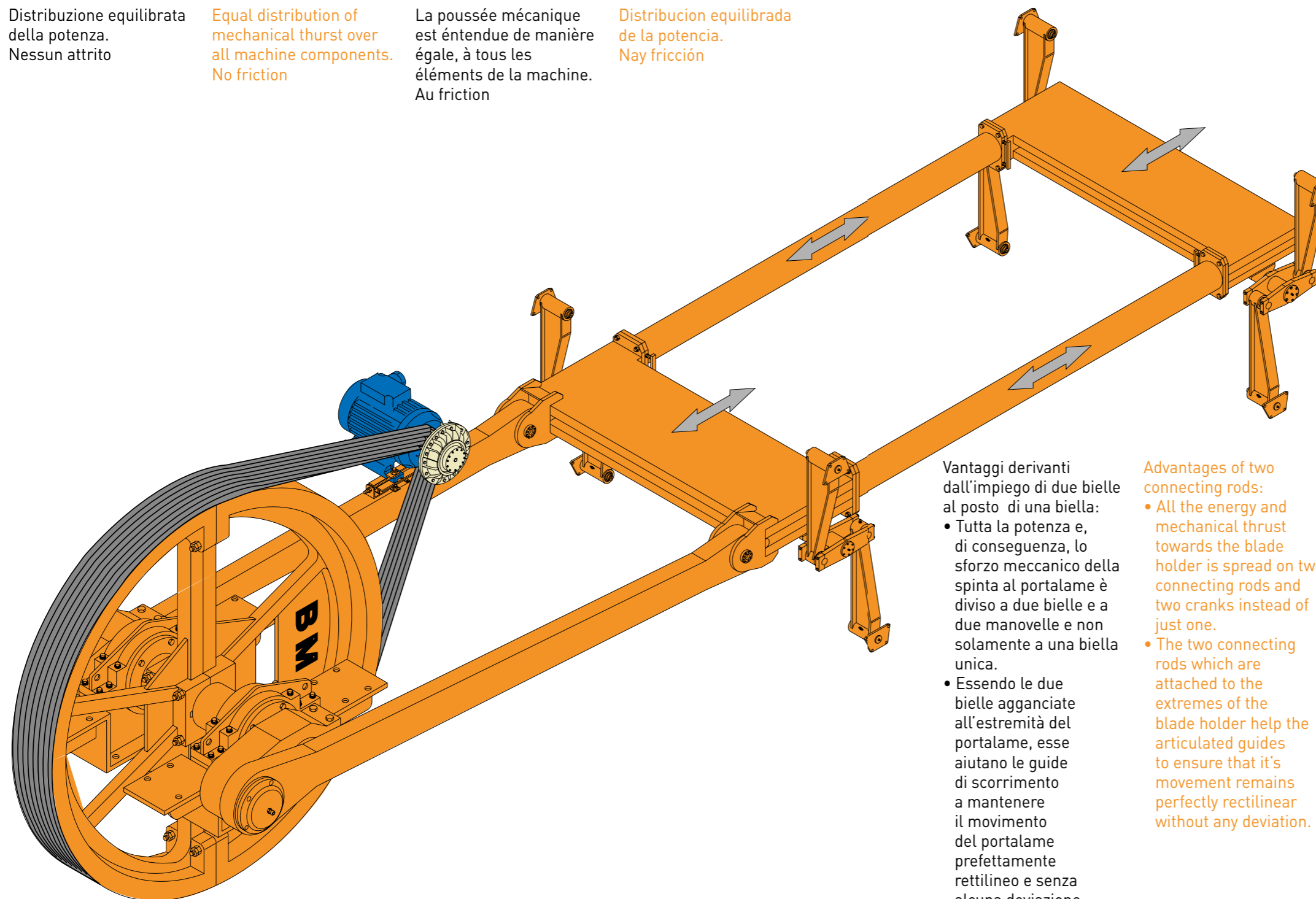

Vantaggi derivanti dall'impiego di due bielle al posto di una biella:

- Tutta la potenza e, di conseguenza, lo sforzo meccanico della spinta al portalamo è diviso a due bielle e a due manovelle e non solamente a una biella unica.
- Essendo le due bielle agganciate all'estremità del portalamo, esse aiutano le guide di scorrimento a mantenere il movimento del portalamo perfettamente rettilineo e senza alcuna deviazione.

Advantages of two connecting rods:

- All the energy and mechanical thrust towards the blade holder is spread on two connecting rods and two cranks instead of just one.
- The two connecting rods which are attached to the extremes of the blade holder help the articulated guides to ensure that its movement remains perfectly rectilinear without any deviation.

Avantages de deux bielles:

- Toute la force et l'effort mécanique de la pousse sur le porte lames sont divisés sur deux bielles et manovelles au lieu que d'une seulement.
- Les deux bielles attachées sur les extrémités du porte-lames aident les guides articulés à maintenir son mouvement parfaitement rectiligne évitant toute déviation.

Ventajas derivadas del empleo de dos bielas en lugar de una:

- Toda la potencia y, por consiguiente, el esfuerzo mecánico del empuje al portalamas, está repartido entre dos bielas y dos manivelas y no gravita sobre una sola biela.
- Dado que las dos bielas están enganchadas a la extremidad del portalamas, las guías de deslizamiento ayudan a mantener el movimiento del portalamas perfectamente rectilíneo y sin ninguna desviación.

Pannello di controllo

Control panel • Panneau de contrôle • Cuadro de mandos



Tutti i componenti elettrici sono standardizzati e delle migliori marche internazionali. Il quadro comandi è dotato, di serie, di automatismi che garantiscono il perfetto funzionamento della macchina anche in assenza dell'operatore. Il quadro può essere dotato di programmatore elettronico per l'autoregolazione della cala secondo il tipo di materiale.

All the electrical components are standard to all our gangsaws and are made by the best international manufacturers. The control panel is automated; a continued presence of an operator is unnecessary. It may also be equipped with an electronic programmer which automatically adjusts the downfeed to the type of material being sawn.

Tous les composants électriques sont standardisés sur toutes nos chassises et sont fournis par les meilleurs fabricants. Le panneau de contrôle est automatisé et ne rend pas nécessaire la présence continue d'un opérateur. Il peut aussi être équipé d'un programmeur électronique qui adapte automatiquement la vitesse de descente des lames au matériel à scier.

Todos los componentes eléctricos están estandarizados y son de las mejores marcas internacionales. El cuadro de mandos está equipado, de serie, con automatismos que aseguran el perfecto funcionamiento de la máquina, incluso en ausencia del operador. El cuadro puede ser provisto de programador electrónico para la autorregulación de la bajada según el tipo de material.

Optionals

Optionals • Optionnelles • Opcionals

- (1) Sensori di sicurezza
- (2) Giunto idraulico
- (3) Sistema di pioggia a canalette aperte
- (4) Touch screen

- (1) safety sensors
- (2) hydraulic coupling
- (3) open-duct water sprinkling system
- (4) touch screen

- (1) capteurs de sûreté
- (2) joint hydraulique
- (3) système d'arrosage à rigoles ouvertes
- (4) touch screen

- (1) sensores de seguridad
- (2) junta hidráulica
- (3) sistema de rociado con canales abiertos
- (4) touch screen



(2)



(4)

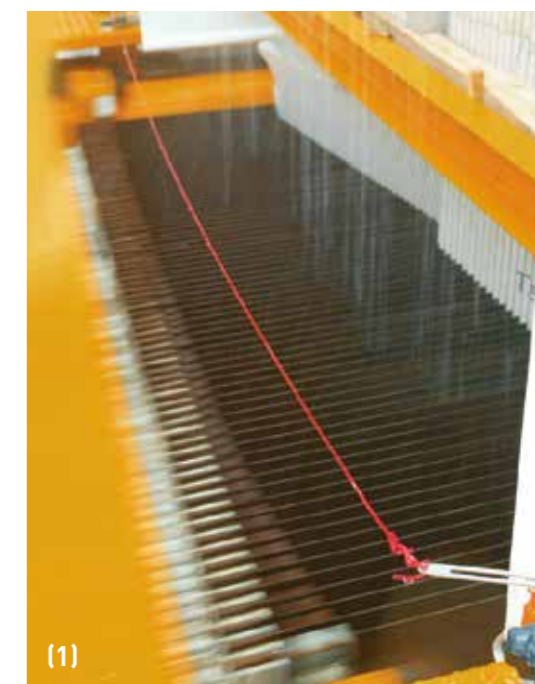

(1)



(3)

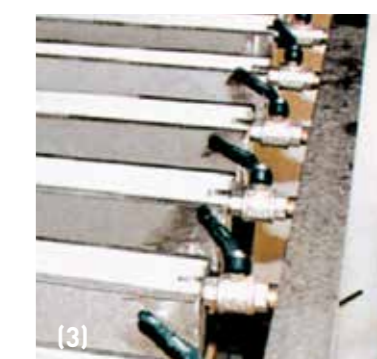

(3)



Entrata carrello

Entrance of the trolley • Entrée du chariot • Entrada del carro

Layout



Il telaio può essere fornito con entrata frontale o laterale del carrello

The frame may be supplied with frontal or side-entry of the block trolley

Le châssis peut aussi être fourni avec l'entrée frontale ou latérale du chariot

El telar puede tener también la entrada frontal y lateral del carro

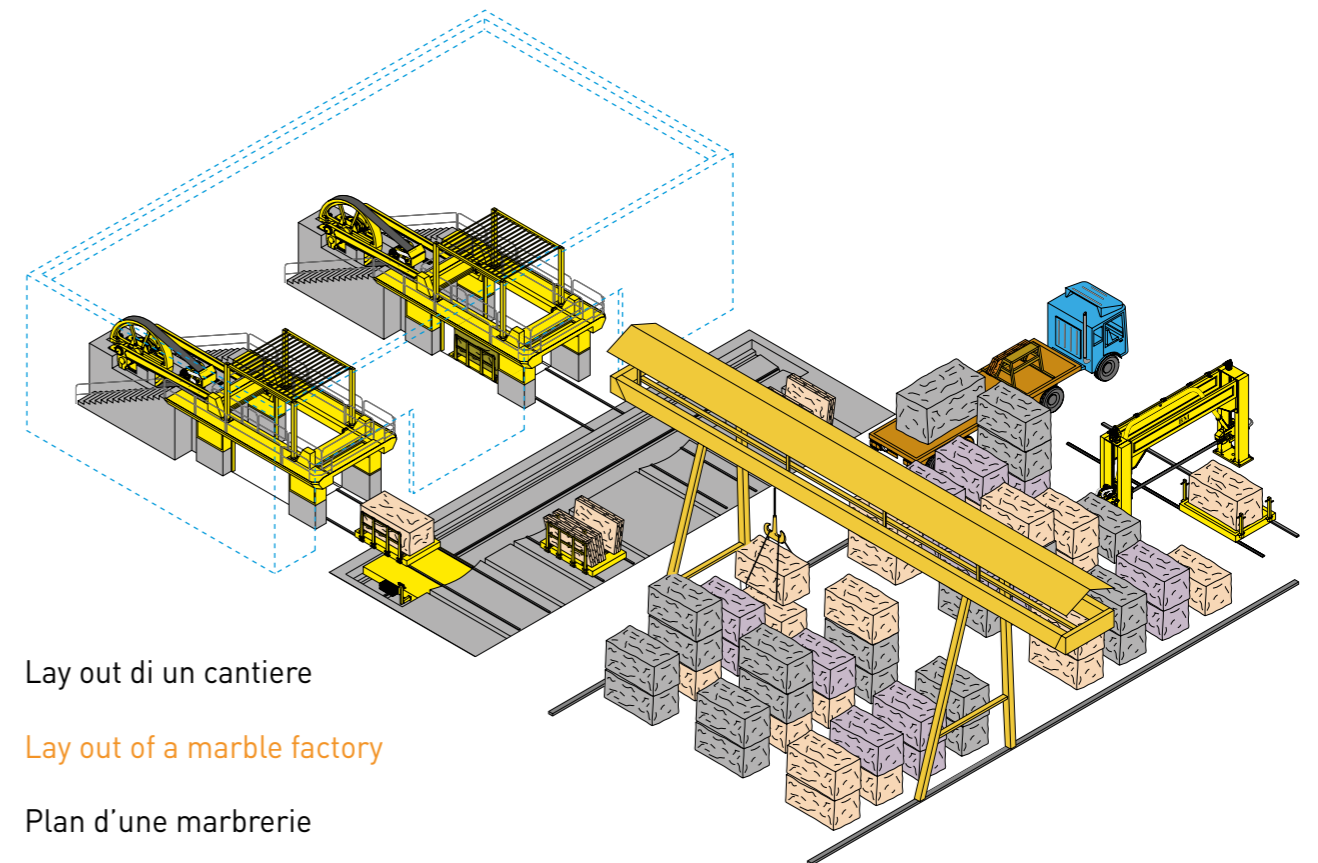

Lay out di un cantiere

Lay out of a marble factory

Plan d'une marbrerie

Lay out de una obra



Caratteristiche Tecniche

Technical data • Caracteristiques techniques • Caracteristicas tecnicas

Modello	A	B	C	D
DIAMOND BM 70	13150	3300	5000	5500
DIAMOND BM 80	13150	3300	5000	5700
DIAMOND BM 100	13150	3300	5000	5700
DIAMOND BM 100 L	13150	3300	5000	6200

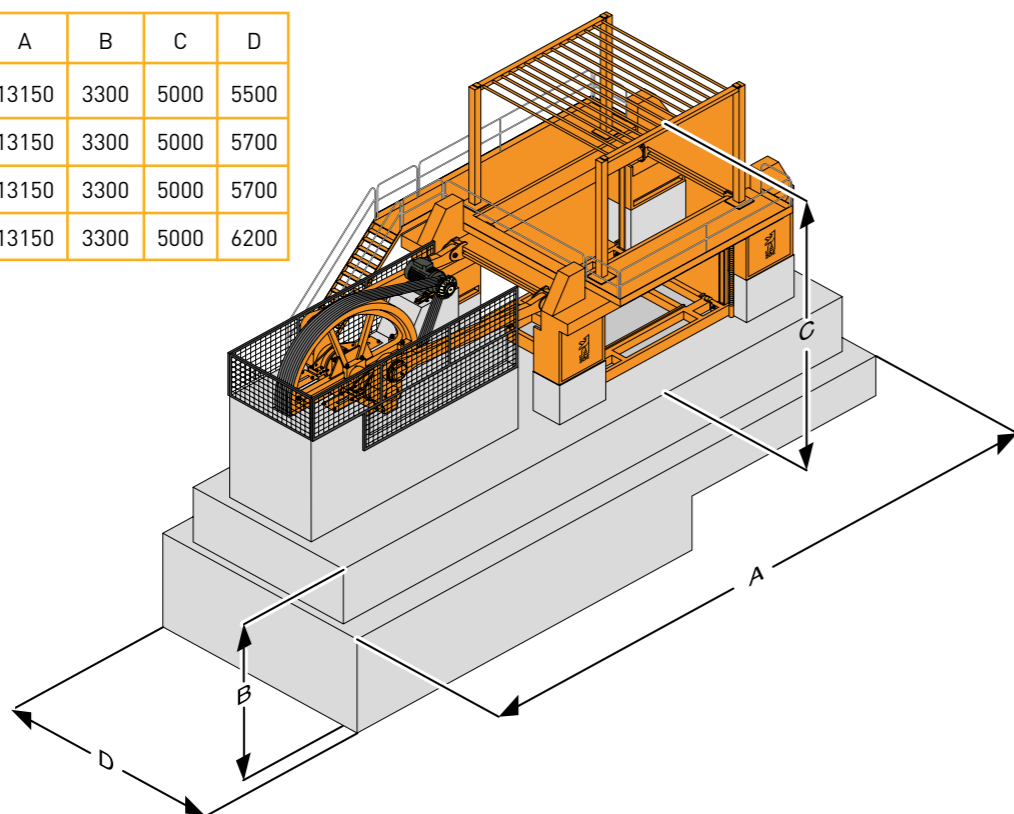

Modello	N° lame Nb. blades N. hojas mm	Lunghezza lame Length of blades Longueur lames Largo hojas mm	Taglio utile Useful cutting size Sciage utile Corte util			Potenza motore Motor power Puissance moteur Potencia motore		Corsa lama Strokes of the blade Course lame Carrera hoja mm	Battute al minuto Cycles per minute Battements par minute Pasadas por minuto	Peso macchina Weight of the frame Poids chassis Peso máquina tons	Dim. carrello Dim. of trolley Dim. chariot Dim. carro mm
			Altezza Height Hateaur Alto mm	Larghezza Width Largeur Ancho mm	Lunghezza Length Longueur Largo mm	Principale Main Principal KW	Apparecchiatura cala rapida Fast lowering rapide Appareillage de descente rapide Grupo bajada veloz KW				
BM 70 SUPER	70	4.400	1.900	1.800	3.200	110	11	800	90	45	1.820 x 3.200
BM 80 SUPER	80	4.400	2.000	2.000	3.200	110	11	800	90	47	2.020 x 3.200
BM 100 SUPER	100	4.400	2.000	2.000	3.200	132	11	800	85	47	2.020 x 3.200
BM 100 L SUPER	100	4.400	2.000	2.500	3.200	132	11	800	85	50	2.520 x 3.200

ACCESSORI A RICHIESTA: Tenditore idraulico, carrello porta-blocchi, tiranti e distanziatori, freno automatico, touch screen per controllo automatico "cala-lavoro"
 ACCESSORIES UPON REQUEST: Hydraulic tensioner, block trolleys, tie rods for blades and spacers, automatic brakes, touch screen for the automatic control of "the sawing"
 ACCESSOIRES SUR DEMANDE: Tendeur hydraulique, chariots porte-blocs, tirants pour lames et épaisseurs, frein automatique, touch screen pour le contrôle automatique de "le sciage"
 ACCESORIOS AL PEDIDO: Tensor hidráulico, carro porta-bloques, tirantes y distanciadore, freno automático, touch screen por control automático de "el corte"
 Le illustrazioni e i dati tecnici sono indicativi. La Ditta si riserva di apportare qualsiasi modifica alle macchine, senza preavvisare il cliente.
 All technical data contained in this catalogue is subject to review and not binding. We reserve the right to modify all aspects of our machinery without prior notice to the customer.
 Les données techniques présentées dans ce catalogue sont fournies à titre indicatif et peuvent être modifiées sans préavis.
 Las ilustraciones y datos técnicos son indicativos. La firma se reserva el derecho de modificar la máquina, sin avisar previamente al cliente.



TELAJ PER LA SEGAGIONE DEI BLOCCHI DI MARMO E GRANITO GANG SAW FOR SAWING MARBLE AND GRANITE BLOCKS

